

Mark 1

Gantrail Resilient Pad For Continuous Rail Support

www.gantrail.com



Gantrail®

A world of crane rail expertise

Mark 1

The use of Gantrail Mark 1 Crane Rail Pad between a rail and its support substantially improves the performance of crane tracks. Cranes apply very high forces to the structures on which they are mounted. The pad significantly reduces the stress between the rail and its support. The Gantrail pad is one of the three key ingredients in achieving a reliable track. These are:-

- Resilient Pad
- Strong, adjustable clips
- Continuously welded rail

SPECIFICATIONS:

The pad width should be nominally 5mm less than the rail foot width.

DIMENSIONS:

PART No	W mm (Flat)
MK1-070	70
MK1-080	80
MK1-090	90
MK1-095	95

* Additional sizes available -
Please contact Gantrail for details

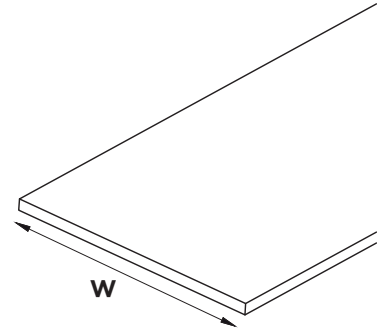

Gantrail flat pad is normally supplied in 10 metre lengths but is also available in lengths and widths to suit customer specification. This may result in longer lead times.

Please contact Gantrail for guidance.

FEATURES

- When used in conjunction with Gantrail adjustable rail clips, Mark 1 crane pad will significantly reduce stresses in the rail, grout and concrete below the soleplate.
- It allows the rail to rotate small amounts so that it conforms to the crane wheel.
- This gives an even distribution of wheel loads onto the supporting structure.

COMPONENTS

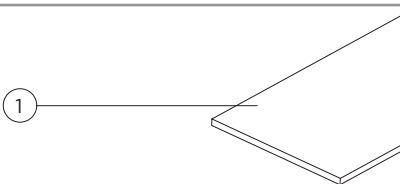

1. Resilient pad

CONTINUOUS SUPPORT

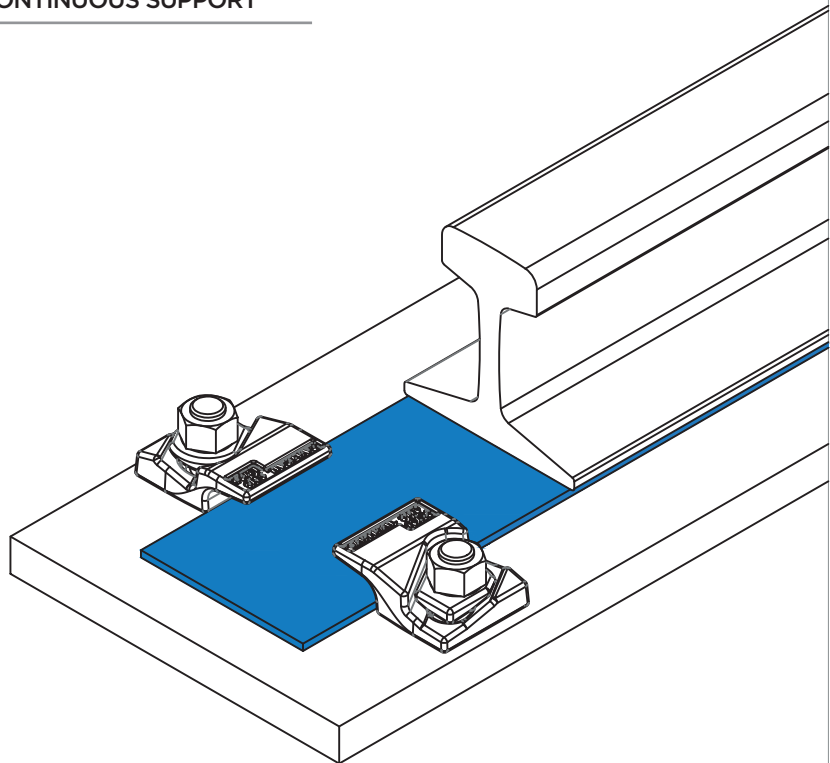

Gantrail can supply standard design details and technical information in support of all crane rail applications.

Mark 1

Gantrail Resilient Pad For Continuous Rail Support

Gantrail Mark 1 pads are manufactured from wear resistant durable vulcanised synthetic rubber. They are unaffected by oil, grease or ultraviolet light. They have been tested to many times the design loads and show complete recovery.

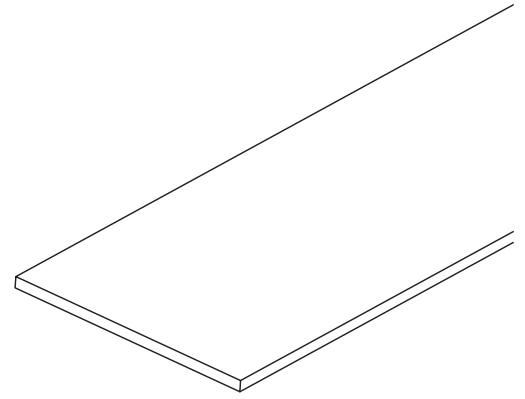

Material	Nitrile rubber	
Shore hardness (ISO 48:1994)	70 +/- Shore A	
Tensile strength (ISO 37:1994)	7 N/mm ²	Minimum
Elongation (ISO 37:1994)	200%	Minimum
Temperature range	-15°C to 70°C	
Oil resistance ASTM Oil No.2	Swelling 5%	Maximum

MARK 1 PROFILE

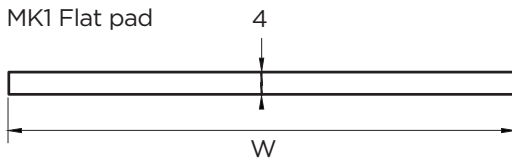

INSTALLATION INSTRUCTIONS:

Rail pad should be narrower than the rail it is supporting (nominally 5mm). The pad is normally supplied in 10 metre lengths. The pad may be cut to precise length of rail. It can be cut with a hacksaw or jigsaw. No installed length of pad should be less than the spacing between three pairs of crane rail fixing clips. Before installing Mark 1 pad, the supporting area should be clean and free of oil, grease or any projections likely to damage the pad. It is preferable that the steel structure below the pad is not painted. If the rail is to be welded the pad should be protected from excessive heat during welding by being removed under the weld or by being protected with a thermal barrier. Our technical department will be pleased to advise on the suitability of Mark 1 pad in specific installation conditions.

A world of crane rail expertise.

www.gantrail.com



Gantrail[®]
A world of crane rail expertise

Gantry Railing Ltd
Sudmeadow Road
Hempsted
Gloucester GL2 5HG
ENGLAND

Tel: +44 (0) 1452 300688
E-mail: info@gantrail.com



Certificate No. 5180

Mark1/DO/03/21